

**Article Info**

Received: 05 Aug 2013 | Revised Submission: 22 Aug 2013 | Accepted: 28 Aug 2013 | Available Online: 20 Sept 2013

**Irriversibility Analysis of Multi-Evaporators Vapour Compression Refrigeration Systems Using New and Refrigerants: R134a, R290, R600, R600a, R1234yf, R502, R404a and R152a and R12, R502**

R. S. Mishra\*

**ABSTRACT**

*The methods for improving first law and second law efficiency have been considered in this paper. Detailed energy and exergy analysis of multi-evaporators at different temperatures with multiple compressors and multiple expansion valves in parallel and series with intercooler and flash chambers in the six type vapour compression refrigeration systems for finding irreversibilities in the systems have been done in terms of performance parameter for eco-friendly R134a, R290, R600, R600a, R1234yf, R1234ze, R404a and R152a and conventional R12, R502 refrigerants. The numerical computations have been carried out for six systems. It was observed that first law and second law efficiency improved by 22%. It was also observed that performance of above six systems using R600 and R152a nearly matching same values under the accuracy of 5% can be used in the above system. But difficulties using R600, R290 and R600a have flammable problems therefore safety measures are required using these refrigerants, therefore R134a refrigerant is recommended for practical and commercial applications although it has slightly less thermal performance than R152a which is not widely used refrigerant for domestic and industrial applications.*

**Keywords:** Vapour Compression Refrigeration Systems First and Second Law Analysis; Irreversibility Analysis in VCR.

**1.0 Introduction**

It is well known the fact that after 90's CFC and HCFC refrigerants have been forbidden due to chlorine content and their high ozone depleting potential (ODP) and global warming potential (GWP). Thus, HFC refrigerants are used nowadays, presenting a much lower GWP value, but still high with respect to non-fluorine refrigerants. Many research papers have been published on this subject, of replacing "old" refrigerants with "new" ones [1-6]. Lately, many papers focused on researches about finding better and better refrigerants or mixtures, considering different criteria, as for example: Relative COP, COP, EDR, exergetic efficiency, and exergy defect in compressor, condenser, expansion valve subcooler and evaporators.

This paper presents a comparative analysis of eight refrigerants working in a multi-evaporators VCR system with subcooling and superheating.

These eight refrigerants are: 1,2-Difluoroethane (R152a), Propane (R290), Butane (R600), Isobutane (R600a), 2,3,3,3-Tetrafluoropropene (R1234yf), a azeotropic blend (R404a), (R410a) and (R502). R404a is a near-azeotropic blend of R125 / R143a / R134a with mass percentages of 44% / 52% / 4%. R410a is an azeotropic blend of Difluoromethane R32 Pentafluorethane R125 with mass percentages of 50% / 50%.

Blends do not necessarily remain at constant temperature during constant pressure evaporation or condensation. This paper mainly deals with a comparative analysis of the refrigerant impact on the performances of six types multi-evaporators multiple compression and multiple expansion valves in series and parallel with introducing intercoolers in the vapor compression refrigeration systems. The aim of this paper is to present and propose an analysis model for comparing the effects of multi-evaporators, Multiple expansion valves in series and parallel combination

\*Corresponding Author: Department of Mechanical Engineering, Delhi Technological University, India  
(E-mail: professor\_rsmishra@yahoo.co.in)

and multiple compressors VCR System for improving first law and second law efficiency with different eco-friendly refrigerants as compared with R12 and R502.

## 2.0 Literature Review

Refrigeration is a technology which absorbs heat at low temperature and provides temperature below the surrounding by rejecting heat to the surrounding at higher temperature. Simple vapour compression system which consists of four major components compressor, expansion valve, condenser and evaporator in which total cooling load is carried at one temperature by single evaporator but in many applications like large hotels, food storage and food processing plants, food items are stored in different compartment and at different temperatures. Therefore there is need of multi evaporator vapour compression refrigeration system. The systems under vapour compression technology consume huge amount of electricity, this problem can be solved by improving performance of system. Performance of systems based on vapour compression refrigeration technology can be improved by following:

- The performance of refrigerator is evaluated in term of first law efficiency (COP) which is the ratio of refrigeration effect to the net work input given to the system.
- The COP of vapour compression refrigeration system can be improved either by increasing refrigeration effect or by reducing work input given to the system.
- It is well known that throttling process in vapour compression refrigeration (VCR) is an irreversible expansion process. Expansion process is one of the main factors responsible for exergy loss in cycle performance because of entering the portion of the refrigerant flashing to vapour in evaporator which will not only reduce the cooling capacity but also increase the size of evaporator. This problem can be eliminated by adopting multi-stage expansion with flash chamber where the flash vapours is removed after each stage of expansion as a consequence there will be increase in cooling capacity and reduce the size of the evaporator.
- Work input can also be reduced by replacing multi-stage compression or compound compression with single stage compression.

- Refrigeration effect can also be increased by passing the refrigerant through subcooler after condenser to evaporator.

Vapour compression refrigeration system based applications make use of refrigerants which are responsible for greenhouse gases, global warming and ozone layer depletion. Montreal protocol was signed on the issue of substances that are responsible for depleting Ozone layer and discovered how much consumption and production of ozone depletion substances took place during certain time period for both developed and developing countries. Another protocol named as Kyoto aimed to control emission of green house gases in 1997[1]. The relationship between ozone depletion potential and global warming potential is the major concern in the field of GRT (green refrigeration technology) so Kyoto proposed new refrigerants having lower value of ODP and GWP. Internationally a program being pursued to phase out refrigerants having high chlorine content for the sake of global environmental problems [2]. Due to presence of high chlorine content, high global warming potential and ozone depletion potential after 90's CFC and HCFC refrigerants have been restricted. Thus, HFC refrigerants are used nowadays, showing much lower global warming potential value, but still high with respect to non-fluorine refrigerants. Lots of research work has been done for replacing "old" refrigerants with "new" refrigerants [3-8]. Reddy et al. (2012) carried out numerical analysis of vapour compression refrigeration system using R134a, R143a, R152a, R404A, R410A, R502 and R507A for finding the effect of evaporator temperature, degree of sub cooling at condenser outlet, superheating of evaporator outlet, vapour liquid heat exchanger effectiveness and degree of condenser temperature on COP and exergetic efficiency. They concluded that evaporator and condenser temperature have significant effect on both COP and exergetic efficiency and also found that R134a gives the better performance while R407C has poor performance in all respect. Selladurai and Saravanakumar (2013) have designed domestic refrigerator which was used R134a as eco-friendly refrigerant and also compared the thermal performance of the system with using another eco-friendly refrigerant as hydrogen mixture (i.e. R290/R600a mixture) and found that

R290/R600a hydrocarbon mixture gives better performance in terms of higher COP and exergetic efficiency than R134a. They also concluded that highest irreversibility obtained in the compressor compare to condenser, expansion valve and evaporator in the domestic refrigeration system. Nikolaidis and Probert (1998) analytically found the considerable effect on plant irreversibility by change in evaporator and condenser temperatures of two stage vapour compression refrigeration plant using R22 refrigerant. They concluded that there is need for optimizing condenser and evaporator conditions. Kumar et al. (1989) carried out energy and exergy analysis of vapour compression refrigeration system using of exergy-enthalpy diagram. They also used detailed first law analysis for calculating the coefficient of performance and second law analysis for evaluating irreversibility in terms of various losses occurred in different components of vapour compression cycle using R11 and R12 as refrigerants.

Mastani Joybari et al. (2013) conducted experiments on a domestic refrigerator originally manufactured to use of 145g of R134a and also concluded exergetic defect occurred in compressor was highest as compare to other components and through their analysis it has been found that instead of 145g of R134a if 60g of R600a is used in the considered system gave same performance which ultimately result into economical advantages and reduce the risk of flammability of hydrocarbon refrigerants.

Anand and Tyagi (2012) carried out detailed exergetic analysis of two ton capacity of window air conditioning test rig with R22 as working fluid and concluded that irreversibility in system components will be highest when the system is 100% charged and lowest when 25% charged and found irreversibility in compressor is highest among other system components.

Arora and Kaushik (2008) studied numerical model of vapour compression refrigeration system with liquid vapour heat exchanger and carried out energy and exergy analysis on the VCR for the specific temperature range of evaporator and condenser. They concluded that R502 is the best refrigerant compare to R404A and R507A, compressor is the worst and liquid vapour heat exchanger is best component of the system. Ahamed et al. (2012) experimentally investigated thermal

performance using hydrocarbons (isobutene and butane) refrigerant on domestic refrigerator by energy and exergy analysis and found that energy efficiency ratio of hydrocarbons is comparable with R134a.

They concluded that exergy efficiency and sustainability index of hydrocarbons is much higher than R134a at evaporator temperature and found that compressors are showing highest system defect (69%) among components of that system. Stanciu et al. (2011) carried out numerical and graphical investigation on one stage vapour compression refrigeration system by using refrigerants (i.e R22, R134a, R717, R507a, and R404a) in terms of COP, compressor work, exergy efficiency and refrigeration effect.

They also studied the effect of sub-cooling, superheating and compression ratio on the same system using considered refrigerants and presented system optimization when working with specific refrigerant. Ahamed et al. (2011) emphasized on use of hydrocarbons and mixture of hydrocarbons and R134a in vapour compression refrigeration system and found that compressor showed much higher exergy destruction as compared to other components of vapour compression refrigeration system and found that exergy destruction can be minimized by using of nanofluid and nanolubricants in compressor.

Bolaji et al. (2011) conducted experimentally comparative analysis of R32, R152a and R134a refrigerants in vapour compression refrigerator concluded that R32 is showing lowest thermal performance and also found that R134a and R152a showing nearly same thermal performance but best performance was obtained of same system using R152a as ecofriendly refrigerant. Yumrutas et al. (2002) carried out detailed exergy analysis and found the effect of condensing and evaporating temperature on vapour compression refrigeration cycle in terms of pressure losses, COP, second law efficiency and exergy losses.

They conclude that the variation in condenser temperature have negligible effect on exergy losses of compressor and expansion valve, and also found that first law efficiency and exergy efficiency increases and total exergy losses of system is decreasing with increasing evaporator and condenser temperatures. Padilla et al. (2010) carried out exergy analysis of domestic vapour compression refrigeration system using R12 and ecofriendly

R413a refrigerant and found that better thermal performance of the system using R413a in terms of power consumption, irreversibility and exergy efficiency is better than R12, and recommended R12 can be replaced by R413a in domestic vapour compression refrigeration system. Getu and Bansal (2008) optimized design and operating parameters of cascade refrigeration system in terms of condensing temperature, sub cooling temperature, evaporating temperature, superheating temperature and temperature difference using cascade heat exchanger R744-R717.

They obtained optimum thermodynamic parameters of same system using regression analysis. Spatz and Motta (2004) carried out experimental investigation by using R410a for replacing R12 for medium temperature vapour compression refrigeration systems in terms of thermal performance.

Detailed thermodynamic analysis is also carried out and comparison was made for heat transfer and pressure drop characteristics and it was found that R410a gives best thermal performance among R12, R404a and R290a. Mohanraj et al. (2009) through experimental investigation concluded the effect of different environmental temperatures on first law efficiency (COP) of domestic refrigeration system using mixture of R290 and R600a in the ratio of 45.2: 54.8 by weight and found 3.6% greater performance than R134a in the same system. They also found the discharge temperature of compressor with mixture of R290 and R600a is lower in the range of 8.5-13.4K than same compressor with R134a. Han et al. (2007) conducted experimental results under different working conditions revealed that there could be replacement of R407C in vapour compression refrigeration system having rotor compressor with mixture of R32/R125/R161 showing higher COP, less pressure ratio and slightly high discharge compressor temperature without any modification in the same system than R-12 which produced global warming and ozone depletion.

Halimic et al. (2003) have compared thermal performance of vapour compression refrigeration system using ecofriendly refrigerants such as R401A, R290 and R134A with R12 and found that due to similar performance of R134a in comparison with R12, the eco friendly refrigerant R134A can be replaced R12 in the same system without any

modification in the system components and also has zero ozone depletion. They also concluded that in reference to green house impact, R290 presented best results than R134a. Xuan and Chen (2004) conducted experimental study on vapour compression refrigeration system for replacement of R502 by mixture of HFC-161 and found that mixture of HFC-161 gives same and higher performance than R404A at lower and higher evaporative temperature respectively. Cabello et al. (2007) had studied about the effect of operating parameters on COP, work input and cooling capacity of single-stage vapour compression refrigeration system. There is great influence on energetic parameters due change in suction pressure, condensing and evaporating temperatures.

Cabello et al. (2004) experimentally investigated the effect of condensing pressure, evaporating pressure and degree of superheating on single stage vapour compression refrigeration system using R22, R134a and R407C. It was observed that mass flow rate is greatly affected by change in suction conditions of compressor in results on refrigeration capacity because refrigeration capacity depended on mass flow rate through evaporator. It was also found that for higher compression ratio R22 gives lower COP than R407C.

Based on the literature it was observed that researchers have gone through detailed first law analysis in terms of coefficient of performance and second law analysis in term of exergetic efficiency of simple vapour compression refrigeration system with single evaporator. Researchers did not go through the irreversibility analysis or second law analysis of: simple VCR with flash intercooler, flash chamber, water intercooler, liquid sub cooler and stages in compression (double stage and triple stage) and multiple evaporators systems with multi-stage expansion and compound compression in vapour compression refrigeration systems.

To improve thermal performance of vapour compression refrigeration systems (both single and multiple evaporator system) by improving:

1. First Law Efficiency
2. Second Law Efficiency
3. Reduction of System

Defect in components of system which results into reduction of work input and detailed analysis of

vapour compression refrigeration systems using ecofriendly refrigerants.

**Energy and Exergy analysis of Vapour compression Refrigeration systems**

The multiple evaporators at the same temperature with single compressor and expansion valve vapour compression refrigerator with subcooler is shown in Fig. 1. According to first law of thermodynamics, the measure of performance of the refrigeration cycle is the coefficient of performance (COP), which is defined as the net refrigeration effect produced per unit of work input. It is expressed as

$$COP = \frac{Q_s}{W_{comp}} \quad (1)$$

The concept of exergy was given by second law of thermodynamics, which always decreases due to thermodynamic irreversibility. Exergy is defined as the measure of usefulness, quality or potential of a stream to cause change and an effective measure of the potential of a substance to impact the environment [7]. Exergy balance for a control volume undergoing steady state process is expressed as [8].

$$IR_k = \sum (me_x)_{in} - \sum (me_x)_{out} + \left[ \sum \left( q \left( 1 - \frac{T_0}{T} \right) \right)_{in} - \sum \left( q \left( 1 - \frac{T_0}{T} \right) \right)_{out} \right] \pm \sum W \quad (2)$$

Where IR<sub>k</sub> indicates the rate of irreversibility occurring in the compressor, expansion valve, evaporators, condenser and sub-cooler

The first two terms on the right hand side represent exergy of streams entering and leaving the control volume. The third and fourth terms are the exergy associated with heat transfer Q from the source maintained at constant temperature T and is equal to work obtained by Carnot engine operating between T and T<sub>0</sub>, and is therefore equal to maximum reversible work that can be obtained from heat energy Q.

The last term is the mechanical work transfer to or from the control volume.

**Irreversibility (IR) in the system components**

Irreversibility in each component of the cycle is calculated as per Eqs. (3)– (9), specified below:  
Evaporator-1

$$IR_{e1} = E_{x4} + Q_{e1} \left( 1 - \frac{T_0}{T_r} \right) - E_{x1} = m_{r1}(h_4 - T_0 s_4) + Q_{e1} \left( 1 - \frac{T_0}{T_r} \right) - m_{r1}(h_1 - T_0 s_1) \quad (3)$$

Evaporator-2

$$IR_{e2} = E_{x4} + Q_{e2} \left( 1 - \frac{T_0}{T_r} \right) - E_{x1} = m_{r2}(h_4 - T_0 s_4) + Q_{e2} \left( 1 - \frac{T_0}{T_r} \right) - m_{r2}(h_1 - T_0 s_1) \quad (4)$$

Evaporator-3

$$IR_{e3} = E_{x4} + Q_{e3} \left( 1 - \frac{T_0}{T_r} \right) - E_{x1} = m_{r3}(h_4 - T_0 s_4) + Q_{e3} \left( 1 - \frac{T_0}{T_r} \right) - m_{r3}(h_1 - T_0 s_1) \quad (5)$$

**Fig 1: Schematic Diagram of a Multi-Evaporators Vapour Compression Refrigeration System.**

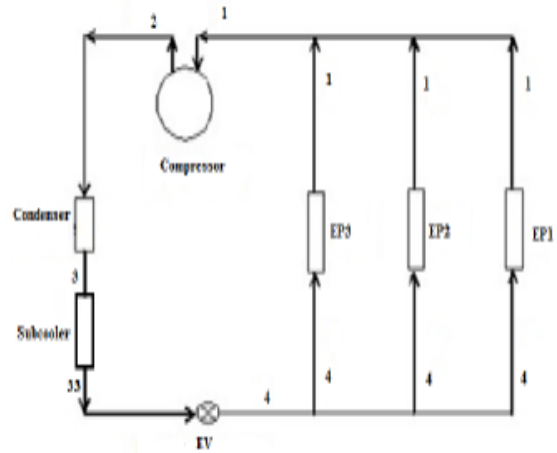

For Compressor

$$IR_{comp} = E_{x1} + W_{comp} - E_{x2} = m_r(T_0 (s_2 - s_1)) \quad (6)$$

Condenser (2)

$$IR_c = E_{x2} - E_{x3} = m_r(h_2 - T_0 s_2) - m_r(h_3 - T_0 s_3) \quad (7)$$

Expansion Valve

$$IR_{eV} = E_{x33} - E_{x4} = m_r(T_0 (s_4 - s_{33})) \quad (8)$$

Subcooler

$$IR_{sc} = E_{x3} - E_{x33} = m_r(h_3 - T_0 s_3) - m_r(h_{33} - T_0 s_{33}) \quad (9)$$

The total irreversibility in the system is the sum of irreversibility in each components of the system and is given by

$$\sum IR_k = IR_{e1} + IR_{e2} + IR_{e3} + IR_{comp} + IR_c + IR_{ev} + IR_{sc} \quad (10)$$

Thermal exergy loss rate in a component is given by

$$EL_k = Q_k \left(1 - \frac{T_0}{T_k}\right) \quad (11)$$

Where  $Q_k$  is the heat rejected by the  $k$ th component and  $T_k$  is the temperature at the boundary of the  $k$ th component. When considering thermal exergy loss rate, Eq. (2) can be rewritten as

$$IR_k + EL_k = \sum (me_x)_{in} - \sum (me_x)_{out} + Q(1 - T_0/T_k) - W \quad (12)$$

Thermal exergy loss rate is related to external irreversibility which takes place because of temperature difference between the control volume and the immediate surroundings. It depends upon how the boundary of the system is selected. If the system includes the immediate surroundings then the boundary of the thermal system is at the same temperature as the temperature of immediate surroundings and hence the value of thermal exergy loss turns out to be zero. However, temperature differential between system boundary and immediate surroundings exists if the system boundary does not include the immediate surroundings. In a vapour compression refrigeration system, condenser is the component where heat is rejected. However in the present case, thermal exergy loss in condenser is neglected as the boundary of the condenser is assumed to be at the environment temperature. Second law performance of the system can be measured in terms of exergetic efficiency [9]. Exergetic efficiency is the ratio between exergy rate of product and fuel. If we consider a system at steady state where, in terms of exergy, the rates at which the fuel is supplied and the product is generated are  $EF$  and  $EP$ , respectively, and  $\sum IR_k$  and  $\sum EL_k$  represent rate of total irreversibility and total thermal exergy loss in a system, respectively, then exergy rate balance for the system is given by (13) and exergetic efficiency by (14).

$$EF = EP + \sum IR_k + \sum EL_k \quad (13)$$

and

$$\eta_{ex} = \frac{\text{Exergy in product}}{\text{Exergy of fuel}} = \frac{EP}{EF} = 1 - \frac{\sum IR_k + \sum EL_k}{EF} \quad (14)$$

For the vapour compression refrigeration system, product is the exergy of the heat abstracted in to the evaporators i.e.  $Q_e = Q_{e1} + Q_{e2} + Q_{e3}$  from the space to be cooled at temperature  $T_r$ , i.e.

$$EP = Q_e \left[1 - \frac{T_0}{T_r}\right] \quad (15)$$

and exergy of fuel is actual compressor work input,  $W_c$ . Hence, exergetic efficiency is given by

$$\eta_{ex} = \frac{Q_e \left[1 - \frac{T_0}{T_r}\right]}{W_{comp}} \quad (16)$$

**Exergy destruction ratio (EDR)** is the ratio of total exergy destruction in the system to exergy in the product [10] and it is given by Eq.(17). EDR is related to the exergetic efficiency by Eq. (18)

$$EDR = \frac{IR_{total}}{EP} = \frac{1}{\eta_{ex}} - 1 \quad (17)$$

$$\eta_{ex} = \frac{1}{1 + EDR} \quad (18)$$

Efficiency defect is defined as the ratio between the exergy flow destroyed in each component and the exergy flow required to sustain the process [11] (i.e. the electrical power supplied to the compressor in the present case) and is given by

$$\delta_k = \frac{\sum IR_k + \sum EL_k}{W_{comp}} \quad (19)$$

where  $k$  stands for particular component. The efficiency defects of the components are linked to the exergetic efficiency of the whole system by means of the following relation:

$$\eta_{ex} = \left(1 - \sum_k \delta_k\right) \quad (20)$$

## 2.0 Models Description of Multiple Evaporators and Compressors with Individual Expansion Valves (System-1) and Multiple Evaporators and Compressors with Multiple Expansion Valves (System-2) Vapour Compression Refrigeration Systems.

The multiple evaporators and compressors with individual expansion valves vapour compression refrigeration system (system-1) consists of compressors (C1, C2, C3 ) throttle valves (TV1, TV2, TV3 ), condenser and evaporators (EP1, EP2, EP3 ) as shown in Fig.1(a). The pressure versus enthalpy chart for this system is shown in Fig.1(b). In this system all refrigerant coming out at point „77“ from subcooler distributed by mass  $m_1$ ,  $m_2$ ,  $m_3$  to expansion valves TV1, TV2, and TV3 respectively. Both liquid and vapour formed by TV1, TV2, TV3 represented

by point „10“, „9“ and „8“ take care the load of EP1 ,EP2 and EP3 respectively. The low pressure vapours formed by EP1 ,EP2 and EP3 supplied to the compressor C1 ,C2 and C3 represented by point „1“, „3“ and „5“ respectively. The high pressure vapours formed by compressor C1 ,C2 and C3 respectively represented by points „2“, „4“ and „6“ .then high pressure vapours coming out from compressor C1 , C1 ,C1 collectively enter through condenser by point „7“. The main components of multiple evaporators and compressors with individual expansion valves vapour compression refrigeration system (system-2) are compressors (C1, C2, C3 ) throttle valves (TV1, TV2, TV3 ), condenser and evaporators(EP1, EP2, EP3 ) as shown in Fig. 2(a)

**Fig 2 a: Schematic Diagram of Multiple Evaporators at Different Temperatures with Individual Compressors and i Ndividual Expansion Valve.**

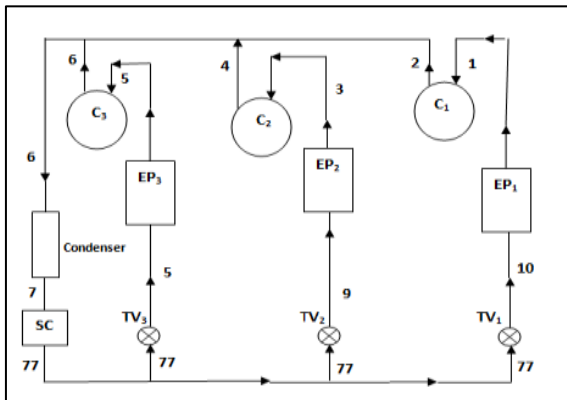

**Fig 2 b: Pressure Enthalpy Diagram of Multiple Evaporators at Different Temperatures with Individual Compressors and Individual Expansion Valves**

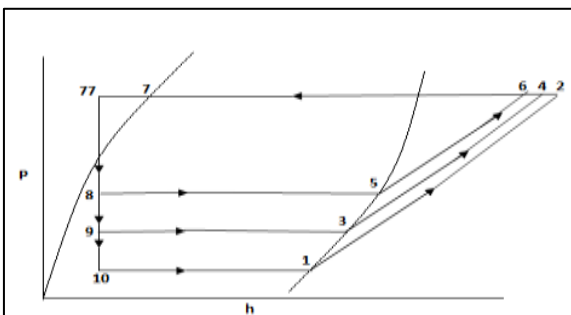

The corresponding pressure versus enthalpy chart for this system is shown in Fig. 2(b).In this system all the refrigerant from condenser at point „g“ followed by subcooler exit at point „gg“ flows through the throttle valve TV3 where its pressure is reduced from condenser pressure of the third evaporator.

All the vapours formed after leaving the expansion valve TV3 at point „h“ plus enough liquid to take care of the load of evaporator EP3.The remaining refrigerant then enter at point „i“ through the expansion valve TV2 where its pressure is reduced from pressure of the third evaporator to pressure of the second evaporator.

**Fig 3 a: Schematic Diagram of Multiple Evaporators at Different Temperatures with Individual Compressors and Multiple Expansion Valves**

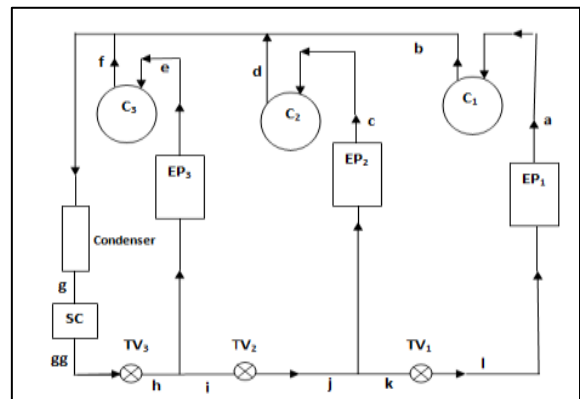

**Fig 3 b: Pressure Enthalpy Diagram of Multiple Evaporators at Different Temperatures with Individual Compressors and Multiple Expansion Valves**

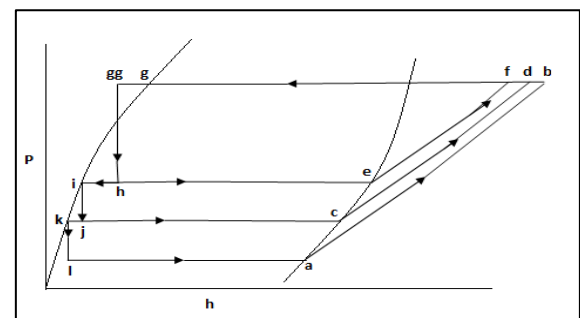

**3.0 First Law Analysis (COP & Work Input Analysis) of Multiple Evaporators and Compressors with Individual or Multiple Expansion Valves Vapour Compression Refrigeration Systems**

Again all the vapour formed after leaving the expansion valve TV2 at point „j“ plus enough liquid to take care of the load of evaporator EP2 passes through this evaporator .The remaining liquid now enter at point „k“ through the expansion valve TV1 and exit at point „l“ which supplied it to the first evaporator EP1.The vapours formed by EP1,EP2 ,EP3 supplied to compressors C1, C2 and C3 shown by point „a“,“c“ and „e“ respectively. High pressure vapours formed by compressors C1, C2 and C3 as shown by points „b“,“d“ and „f“ respectively supplied to the condenser.

The multiple evaporators and compressors with individual or multiple expansion valves vapour compression refrigeration system as shown in Fig.1 and Fig.2 respectively. From the energy analysis point of view first law of thermodynamics, evaluate the performance of the vapour compression systems as given below System-1

$$COP1 = \frac{Q_{e_1}}{W_{comp_1}} \tag{1b}$$

Similarly for system-2

$$COP2 = \frac{Q_{e_2}}{W_{comp_2}} \tag{1c}$$

**3.1 Second law analysis of multiple evaporators and compressors with individual or multiple expansion valves vapour compression refrigeration system**

Second law of thermodynamics gives the concept of exergy, which always decreases due to thermodynamic irreversibility. Exergy is defined as the measure of usefulness, quality or potential of a stream to cause change and an effective measure of the potential of a substance to impact the environment [7]. Exergy balance for a control volume undergoing steady state process is expressed as [8].

$$\dot{E}D_k = \sum(\dot{m}e_x)_{in} - \sum(\dot{m}e_x)_{out} + \left[ \sum \left( \dot{Q} \left( 1 - \frac{T_0}{T} \right) \right) \right] \tag{2b}$$

Where  $\dot{E}D_k$  represents the rate of irreversibility occurring in compressors, throttle valves, evaporators, condenser and subcooler. The first two terms on the right hand side represent exergy of streams entering and leaving the control volume. The third and fourth terms are the exergy associated with heat transfer  $Q$  from the source maintained at constant temperature  $T$  and is equal to work obtained by Carnot engine operating between  $T$  and  $T_0$ , and is therefore equal to maximum reversible work that can be obtained from heat energy  $Q$  . The last term is the mechanical work transfer to or from the control volume. Exergy destruction (ED) in system-1 can be find out in terms of irreversibilities. Exergy destruction in each component of the multiple evaporators and compressors with individual expansion valves vapour compression refrigeration system is evaluated as per Eqs. (3b)– (14b) given below:

**Evaporators**

(EP1) System-1

$$\begin{aligned} \dot{E}D_{e1} &= \dot{E}_{x10} + \dot{Q}_{e1} \left( 1 - \frac{T_0}{T_{r1}} \right) - \dot{E}_{x1} \\ &= \dot{m}_{e1}(\psi_{10} - T_0s_{10}) + \dot{Q}_{e1} \left( 1 - \frac{T_0}{T_{r1}} \right) - \dot{m}_{e1}(\psi_1 - T_0s_1) \end{aligned} \tag{3b}$$

(EP2) System-1

$$\begin{aligned} \dot{E}D_{e2} &= \dot{E}_{x9} + \dot{Q}_{e2} \left( 1 - \frac{T_0}{T_{r2}} \right) - \dot{E}_{x3} \\ &= \dot{m}_{e2}(\psi_9 - T_0s_9) + \dot{Q}_{e2} \left( 1 - \frac{T_0}{T_{r2}} \right) - \dot{m}_{e2}(\psi_3 - T_0s_3) \end{aligned} \tag{4b}$$

(EP3) System-1

$$\begin{aligned} \dot{E}D_{e3} &= \dot{E}_{x8} + \dot{Q}_{e3} \left( 1 - \frac{T_0}{T_{r3}} \right) - \dot{E}_{x5} \\ &= \dot{m}_{e3}(\psi_8 - T_0s_8) + \dot{Q}_{e3} \left( 1 - \frac{T_0}{T_{r3}} \right) - \dot{m}_{e3}(\psi_5 - T_0s_5) \end{aligned} \tag{5b}$$

**Compressors**

$$(C_1)_{System-1} \quad \dot{E}D_{comp 1} = \dot{E}_{x1} + \dot{W}_{comp 1} - \dot{E}_{x2} = \dot{m}_{c1}(T_0(s_2 - s_1)) \tag{6b}$$

$$(C_2)_{System-1} \quad \dot{E}D_{comp 2} = \dot{E}_{x3} + \dot{W}_{comp 2} - \dot{E}_{x4} = \dot{m}_{c2}(T_0(s_4 - s_3)) \tag{7b}$$

$$(C_3)_{System-1} \quad \dot{E}D_{comp 3} = \dot{E}_{x5} + \dot{W}_{comp 3} - \dot{E}_{x6} = \dot{m}_{c3}(T_0(s_6 - s_5)) \tag{8b}$$



**(Condenser) System-1**

$$\dot{E}D_c = (\dot{E}_{x2} - \dot{E}_{x7}) + (\dot{E}_{x4} - \dot{E}_{x7}) + (\dot{E}_{x6} - \dot{E}_{x7}) \quad (9b)$$

**Subcooler**

(SC) System-1

$$\dot{E}D_{sc} = \dot{E}_{x7} - \dot{E}_{x77} = (\dot{m}_{c1} + \dot{m}_{c2} + \dot{m}_{c3})((\psi_7 - T_0 s_7) - (\psi_{77} - T_0 s_{77})) \quad (10b)$$

**Throttle valves**

(TV<sub>1</sub>) System-1

$$\dot{E}D_{TV_1} = \dot{E}_{x77} - \dot{E}_{x10} = \dot{m}_{c1}(T_0(s_{10} - s_{77})) \quad (11b)$$

(TV-2) System-1

$$\dot{E}D_{TV_2} = \dot{E}_{x77} - \dot{E}_{x9} = \dot{m}_{c2}(T_0(s_9 - s_{77})) \quad (12b)$$

(TV-3) System-1

$$\dot{E}D_{TV_3} = \dot{E}_{x77} - \dot{E}_{x8} = \dot{m}_{c3}(T_0(s_8 - s_{77})) \quad (13b)$$

(Mass balance) System-1

$$\dot{m}_{e1} = \dot{m}_{c1}$$

$$\dot{m}_{e2} = \dot{m}_{c2}$$

$$\dot{m}_{e3} = \dot{m}_{c3}$$

The total irreversibility in the system is the sum of irreversibility in each components of the system and is given by

$$\sum \dot{E}D_k = \dot{E}D_{e1} + \dot{E}D_{e2} + \dot{E}D_{e3} + \dot{E}D_{comp1} + \dot{E}D_{comp2} + \dot{E}D_{comp3} + \dot{E}D_c + \dot{E}D_{sc} + \dot{E}D_{TV_1} + \dot{E}D_{TV_2} + \dot{E}D_{TV_3} \quad (14b)$$

For system 2, exergy destruction in each component of the multiple evaporators and compressors with multiple expansion valves vapour compression refrigeration system is evaluated as per Eqs. (15)– (26) given below: Evaporators

(EP1) System-2

$$\begin{aligned} \dot{E}D_{e1} &= \dot{E}_{x1} + \dot{Q}_{e1} \left(1 - \frac{T_0}{T_{r1}}\right) - \dot{E}_{xa} \\ &= \dot{m}_{e1}(\psi_1 - T_0 s_1) + \dot{Q}_{e1} \left(1 - \frac{T_0}{T_{r1}}\right) - \dot{m}_{e1}(\psi_a - T_0 s_a) \end{aligned} \quad (15)$$

(EP2) System-2

$$\begin{aligned} \dot{E}D_{e2} &= \dot{E}_{xj} + \dot{Q}_{e2} \left(1 - \frac{T_0}{T_{r2}}\right) - \dot{E}_{xc} \\ &= \dot{m}_{e2}(\psi_j - T_0 s_j) + \dot{Q}_{e2} \left(1 - \frac{T_0}{T_{r2}}\right) - \dot{m}_{e2}(\psi_c - T_0 s_c) \end{aligned} \quad (16)$$

(EP3) System-2

$$\begin{aligned} \dot{E}D_{e3} &= \dot{E}_{xh} + \dot{Q}_{e3} \left(1 - \frac{T_0}{T_{r3}}\right) - \dot{E}_{xe} \\ &= \dot{m}_{e3}(\psi_h - T_0 s_h) + \dot{Q}_{e3} \left(1 - \frac{T_0}{T_{r3}}\right) - \dot{m}_{e3}(\psi_e - T_0 s_e) \end{aligned} \quad (17)$$

**Compressors**

(C-1) System-2

$$\dot{E}D_{comp1} = \dot{E}_{xa} + \dot{W}_{comp1} - \dot{E}_{xb} = \dot{m}_{c1}(T_0(s_b - s_a)) \quad (18)$$

(C-2) System-2

$$\dot{E}D_{comp2} = \dot{E}_{xc} + \dot{W}_{comp2} - \dot{E}_{xd} = \dot{m}_{c2}(T_0(s_d - s_c)) \quad (19)$$

(C-3) System-2

$$\dot{E}D_{comp3} = \dot{E}_{xe} + \dot{W}_{comp3} - \dot{E}_{xf} = \dot{m}_{c3}(T_0(s_f - s_e)) \quad (20)$$

Condenser) System-2

$$\begin{aligned} \dot{E}D_{cond} &= (\dot{E}_{xb} - \dot{E}_{xg}) + (\dot{E}_{xd} - \dot{E}_{xg}) + (\dot{E}_{xf} - \dot{E}_{xg}) \\ &= \dot{m}_{c1}((\psi_b - T_0 s_b) - (\psi_g - T_0 s_g)) + \dot{m}_{c2}((\psi_d - T_0 s_d) - (\psi_g - T_0 s_g)) \\ &\quad + \dot{m}_{c3}((\psi_f - T_0 s_f) - (\psi_g - T_0 s_g)) \end{aligned} \quad (21)$$

(SC) System-2

$$\dot{E}D_{sc} = \dot{E}_{xg} - \dot{E}_{xgg} = (\dot{m}_{c1} + \dot{m}_{c2} + \dot{m}_{c3})((\psi_g - T_0 s_g) - (\psi_{gg} - T_0 s_{gg})) \quad (22)$$

Throttle valves

(TV-1) System-2

$$\dot{E}D_{TV_1} = \dot{E}_{xk} - \dot{E}_{xl} = \dot{m}_{c1}(T_0(s_l - s_k)) \quad (23)$$

(TV-2) System-2

$$\dot{E}D_{TV_2} = \dot{E}_{xi} - \dot{E}_{xj} = (\dot{m}_{c1} + \dot{m}_{c2})(T_0(s_j - s_i)) \quad (24)$$

(TV-3) System-2

$$\dot{E}D_{TV_3} = \dot{E}_{xgg} - \dot{E}_{xh} = (\dot{m}_{c1} + \dot{m}_{c2} + \dot{m}_{c3})(T_0(s_h - s_{gg})) \quad (25)$$

(Mass balance) System-2

$$\dot{m}_{c1} = \dot{m}_{e1}$$

$$\dot{m}_{c2} = \dot{m}_{e2} = \dot{m}_2 + \dot{m}_{e1} \left( \frac{\phi_j}{1 - \phi_j} \right)$$

$$\dot{m}_2 = \left( \frac{\dot{Q}_{e2}}{\psi_c - \psi_j} \right)$$

$$\dot{m}_{c3} = \dot{m}_{e3} = \dot{m}_3 + (\dot{m}_{e1} + \dot{m}_{e2}) \left( \frac{\phi_h}{1 - \phi_h} \right)$$

$$\dot{m}_3 = \left( \frac{\dot{Q}_{e3}}{\psi_e - \psi_h} \right)$$

The total irreversibility in the system is the sum of irreversibility in each components of the system and is given by

$$\begin{aligned} \sum \dot{E}D_k &= \dot{E}D_{e1} + \dot{E}D_{e2} + \dot{E}D_{e3} + \dot{E}D_{comp1} + \dot{E}D_{comp2} + \dot{E}D_{comp3} + \dot{E}D_c + \dot{E}D_{sc} \\ &\quad + \dot{E}D_{TV_1} + \dot{E}D_{TV_2} + \dot{E}D_{TV_3} \end{aligned} \quad (26)$$

For the multi evaporators vapour compression refrigeration system, product is the exergy of the heat abstracted in to the evaporators i.e.  $Q_{e1} + Q_{e2} + Q_{e3}$  from the space to be cooled at temperature  $T_r$ , and exergy of fuel is actual compressor work input

$$\dot{E}P = \dot{Q}_{e1} \left(1 - \frac{T_0}{T_{r1}}\right) + \dot{Q}_{e2} \left(1 - \frac{T_0}{T_{r2}}\right) + \dot{Q}_{e3} \left(1 - \frac{T_0}{T_{r3}}\right) \quad (27a)$$

Hence, exergetic efficiency is given by

$$\eta_{ex} = \frac{\dot{Q}_{e1} \left(1 - \frac{T_0}{T_{r1}}\right) + \dot{Q}_{e2} \left(1 - \frac{T_0}{T_{r2}}\right) + \dot{Q}_{e3} \left(1 - \frac{T_0}{T_{r3}}\right)}{(W_{comp 1} + W_{comp 2} + W_{comp 3})} \quad (27b)$$

### Result and Discussion

A computational model is developed for carrying out the energy and exergy analysis of the system using EES software [12]. The result evaluated on the basis of following assumed data shown Figs.2 are furnished below:

Degree of sub cooling of liquid refrigerant in subcooler ( $\Delta T_{sc}$ ): 5K., Isentropic efficiency of compressor ( $\eta_c$ ): 75%. , Difference between evaporator and space temperature ( $T_r - T_e$ ): 5K., Temperature of evaporators EP1, EP2 and EP3 are 263K, 273K and 283K respectively, Condenser temperature ( $T_c$ ): 313K, Dead state temperature ( $T_0$ ): 298K, Dead state enthalpy ( $h_0$ ) and entropy ( $s_0$ ) of the refrigerants have been calculated corresponding to the dead state temperature ( $T_0$ ) of 298K., Loads on the evaporators EP1, EP2 and EP3 are 35KW, 70KW and 105KW respectively., Evaporators' temperature is 273K., Condenser temperature ( $T_c$ ): 313K (the condenser temperature is based on climatic conditions persisting in summer in tropical countries)..., Reference enthalpy ( $h_0$ ) and entropy ( $s_0$ ) of the working fluids have been computed corresponding to the dead state temperature ( $T_0$ ) of 298K.. Loads on the evaporators EP1, EP2 and EP3 are 35KW, 70KW and 105KW respectively.

Table-1: presents the variation of coefficient of performance for all six systems for different ecofriendly refrigerants and Bar charts are shown in Table1. It was observed that COP of R12 in all six

Both  $Q_e$  and  $W_c$  have positive effect on increase of exergetic efficiency whereas the decreasing value of term  $|1 - T_0 / T_r|$  has a negative effect on increase of exergetic efficiency. The combined effect of these factors is to increase the exergetic efficiency till the optimum evaporators' temperature is achieved, i.e. the evaporators' temperature at which maximum exergetic efficiency is achieved. Beyond optimum evaporators' temperature, the overall effect of these factors is to reduce the exergetic efficiency. Both R600 and R152a have higher exergetic efficiency than R502,

cases are higher but due to consideration of global warming and ozone depletion one can consider ecofriendly refrigerants for reducing global warming and ozone depletion. The cop of 600 is although is better than R152a but the refrigerants R290, R600 and R600a are flammable properties. Therefore by consideration of safety measures R152a gives better first law performance than R404a, R134a and R410a. With increase in evaporators' temperature, the pressure ratio across the compressor reduces causing compressor work to reduce and cooling capacity increases because of increase in specific refrigerating effect. The combined effect of these two factors is to increase the overall COP. It was observed that COP of system using R600 and R152a nearly matching same values Both R-600 and R-152a show better COP than R-502, R-290, R-404a, R-410a, R-600a and R-1234yf at 313K condenser temperature. Although R600, R600a and R290 have flammable properties cannot use directly due to safety measures, the system will be modified by taking into the considerations safety measures and precautions must be taken when using these refrigerants and also they are responsible for global warming. The maximum difference observed between COPs of R-152a and R-404a is 22.57% at 313K condenser temperature. Table-2 show the effect of ecofriendly refrigerants on exergetic efficiency at 313K condenser temperature. The increase and decrease of the exergetic efficiency, with increase in evaporators temperature, are based on two parameters. First parameter is exergy of cooling effect, i.e.,  $Q_e |1 - T_0 / T_r|$  with rise in evaporators temperature  $Q_e$ , increases however the term  $Q_e |1 - T_0 / T_r|$  reduces since  $T_r$  approaches  $T_0$ , and second being the compressor work which decreases with increase in evaporators temperature.

R290, R404a, R410a, R600a and R1234yf. Exergetic efficiency of R152a is 15–22% higher than R404A and R600 is 12– 20% higher than R404aA at 313K condenser temperature. This also confirms that with increase in condenser temperature the difference among the exergetic efficiency of R152a, R600 and its alternate refrigerants increases. It is observed from Table.2 - Table.3, that variation of EDR and exergetic efficiency are almost reverse because that exergetic efficiency is inversely proportional to EDR. The EDR initially decreases and then increases with the increase in evaporators' temperature. The exergetic

efficiency is inversely proportional to EDR. For a fixed condenser temperature, the increase in dead state temperature causes the irreversibility (due to finite temperature difference) to decrease and hence EDR decreases and exergetic efficiency increases. Table3: presents that R-404a shows maximum EDR among all the refrigerants corresponding to the range of dead state temperatures considered. Both R-152a and R-600 show the identical trends .The exergetic efficiency for R-600 is 0.4-0.5% higher than that of R-152a. It was observed that the effect of degree of subcooling on COP, exergetic efficiency and EDR. It is evident that subcooling increases refrigeration capacity whereas there is no change in compressor work, hence COP increases. It apparent that increase in COP decreases EDR and increases exergetic efficiency. The increase in COP is nearly 5.6%/K of sub cooling in case of R-404a.However, the corresponding increase in COP in R-152a and R-600 is less. The rate of increase of exergetic efficiency is approximately 0.4%/K for R404a.The total increase in exergetic efficiency for 10K of subcooling is 3.97% for R404a and 2.5% for R152a and R-600 at 313K condenser temperature. Hence it is easy to understand why EDR increases and exergetic efficiency decreases. It is observed that COP and exergetic efficiency are almost same for considered eco-friendly refrigerants as compared with R-12 refrigerant, both COP and EDR will decrease with increase in condenser temperature. EDR increase with increase in condenser temperature rational efficiency with increase in condenser temperature at 273K temperature of all evaporators with 5K degree of subcooling.

**Table: 1. Variation of First Law Efficiency (COP) of Multiple Evaporators Vapour Compression Refrigeration Systems Using Eco-Friendly Refrigerants**

Refrigerants	COP(Coefficient of Performance)					
	System1	System2	System3	System4	System5	System6
Previously used						
R12	3.117	3.397	4.078	5.243	6.745	5.205
R502	2.819	3.189	3.838	5.033	6.39	4.994
Suggested new ecofriendly refrigerants						
R152a	3.173	3.425	4.122	5.276	6.822	5.246
R290	2.983	3.308	3.97	5.145	6.582	5.105
R404a	2.649	3.072	3.685	4.893	6.145	4.835
R410a	2.856	3.192	3.842	4.983	6.386	4.959
R600	3.186	3.473	4.145	5.334	6.862	5.294

R600a	3.061	3.392	4.055	5.277	6.743	5.237
R1234yf	2.887	3.284	3.933	5.18	6.569	5.141
R1234ze	3.02	3.373	4.036	5.267	6.763	5.14
R134a	3.034	3.354	4.031	5.227	6.689	5.188

**Table: 2. Variation of Second Law Efficiency of Multiple Evaporators Vapour Compression Refrigeration Systems Using Eco-Friendly Refrigerants**

Refrigerants	Second Law efficiency (Exergetic Efficiency)					
	System1	System2	System3	System4	System5	System6
Previously used						
R12	0.187	0.2913	0.3496	0.3146	0.4047	0.3123
R502	0.1691	0.2734	0.329	0.302	0.3834	0.2996
Suggested new ecofriendly refrigerants						
R152a	0.1904	0.2937	0.3534	0.3166	0.4093	0.3147
R290	0.179	0.2836	0.3404	0.3087	0.3949	0.3063
R404a	0.1589	0.2634	0.3159	0.2936	0.3687	0.2901
R410a	0.1714	0.2737	0.3294	0.2989	0.3831	0.2975
R600	0.1911	0.2978	0.3554	0.3201	0.4117	0.3177
R600a	0.1837	0.2908	0.3477	0.3166	0.4046	0.3142
R1234yf	0.1732	0.2816	0.3372	0.3108	0.3942	0.3085
R1234ze	0.1812	0.2892	0.346	0.316	0.3958	0.3095
R134a	0.182	0.2876	0.3456	0.3136	0.4013	0.3113

**Table: 3. Variation of Exergy Destruction Ratio (EDR) of Multiple Evaporators Vapour Compression Refrigeration Systems Using Eco-Friendly Refrigerants**

Refrigerant	EDR					
	System1	System2	System3	System4	System5	System6
Previously used						
R12	4.253	2.02	1.86	2.255	1.47	2.2
R502	5.262	2.192	2.039	2.412	1.608	2.335
Suggested new ecofriendlyrefrigerants						
R152a	4.045	2.003	1.829	2.229	1.442	2.173
R290	4.695	2.092	1.938	2.326	1.532	2.263
R404a	5.829	2.282	2.165	2.504	1.711	2.424
R410a	5.027	2.207	2.035	2.431	1.607	2.349
R600	4.051	1.953	1.814	2.2	1.429	2.147
R600a	4.426	2.011	1.876	2.247	1.472	2.182
R1234yf	4.952	2.088	1.965	2.313	1.537	2.242
R1234ze	4.586	2.024	1.89	2.256	2.902	2.565
R134a	4.504	2.049	1.894	2.274	1.491	2.211

#### 4.0 Conclusions

In this paper, first law and second law analysis of six multi-evaporators multiple compressor and

multiple expansion valves in series and parallel combinations of vapour compression refrigeration systems using ecofriendly refrigerants (R410a, R290, R600, R600a, R1234yf, R502, R404a and R152a) have been presented. The conclusions of the present analysis are summarized below:

1. COP and exergetic efficiency for R152a and R600 are matching the same values. are better than that for R404A at 313K condenser temperature and showing 12–23% higher value of COP and exergetic efficiency in comparison to R404a.
2. For practical applications R-134a is recommended because it is easily available in the market has second law efficiency slightly lesser than R-152a which was not applicable for commercial applications.
3. The worst component from the viewpoint of irreversibility is expansion valve followed by condenser, compressor and evaporators, respectively. The most efficient component found to be subcooler. The R-152a has least efficiency defects for 313K condenser temperature.
4. The increase in dead state temperature has a positive effect on exergetic efficiency and EDR, i.e. EDR decreases and exergetic efficiency increases with increase in dead state temperature. Both R-152a and R-600 show the identical trends for exergetic efficiency are nearly overlapping. The exergetic efficiency for R-600 is 0.4-0.5% higher than that of R-152a for the practical range of dead state temperature considered.

## References

- [1] M. Padilla, R. Revellin, J. Bonjour, “Exergy analysis of R413A as replacement of R12 in a domestic refrigeration system”, *Energy Conversion and Management* 51, 2195–2201, 2010
- [2] H. O. Spauschus, “HFC 134a as a substitute refrigerant for CFC 12”, *Int J Refrig* 11: 389–92, 1988
- [3] J. U. Ahamed, R. Saidur, H. H. Masjuki, “A review on exergy analysis of vapor compression refrigeration system”, *Renewable*

and Sustainable Energy Reviews 15, 1593–1600, 2011

- [4] R. Llopis, E. Torrella, R. Cabello, D. Sánchez, “Performance evaluation of R404A and R507A refrigerant mixtures in an experimental double-stage vapour compression plant”, *Applied Energy* 87, 1546–1553, 2010
- [5] A. Arora, S. C. Kaushik, “Theoretical analysis of a vapour compression refrigeration system with R502, R404A and R507A”, *International Journal of Refrigeration* 31, 998 – 1005, 2008
- [6] V. Havelsky, “Investigation of refrigerating system with R12 refrigerant replacements”, *Appl Therm Eng*; 20: 133–40 2000
- [7] I. Dincer, “Refrigeration Systems and Applications”, Wiley, UK, p. 26. 2003
- [8] S. F. Lee, S. A. Sherif, “Second law analysis of various double effect lithium bromide/water absorption chillers”, *ASHRAE Transactions* AT-01-9-5, 664–673, 2001
- [9] S. A. Said, B. Ismail, “Exergetic assessment of the coolants HCFC123, HFC134a, CFC11 and CFC12”, *Energy* 19 (11), 1181–1186, 1994
- [10] T. J. Kotas, “The Exergy Method of Thermal Plant Analysis. Butterworths”, London, pp. 73–74, 1985
- [11] S. A. Klein, F. Alvarado, “Engineering Equation Solver”, Version 7.441. F Chart Software, Middleton, WI, 2005

## Nomenclature

COP	coefficient of performance (non-dimensional)
VCR	vapour compression refrigeration
CFC	chlorofluorocarbon
HCFC	hydrochlorofluorocarbon
Q	rate of heat transfer (kW)
W	work rate (kW)
T	temperature (K)
$\delta$	efficiency defect (non-dimensional)
$\Delta T_{sc}$	degree of subcooling

EP	exergy rate of product (kW)	m	mass flow rate (kg/s)
EV	Expansion Valve	s	specific entropy (kJ/kgK)
EP	Evaporator	EF	exergy rate of fuel (kW)
		EL	exergy loss rate (kW)
<b>Subscript</b>		$\eta$	efficiency (non-dimensional)
e	evaporator	r	refrigerant, space to be cooled
comp	compressor	ex	exergetic
h	specific enthalpy (kJ/kg)	ev	expansion valve
P	pressure (kPa)	c	condenser
IR	irreversibility (kW)	sc	subcooler
Ex	exergy rate of fluid (kW)	k	kth component